

# DIGITAL SPEEDOMETER

NARENDRA WADHWANI

This instrument displays the speed of the vehicle in kmph. An opaque disc is mounted on the spindle attached to the front wheel of the vehicle. The disc has ten equidistant holes on its periphery. On one side of the disc an infrared LED is fixed and on the opposite

side of the disc, in line with the IR LED, a phototransistor is mounted. IC LM324 is wired as a comparator.

When a hole appears between the IR LED and phototransistor, the phototransistor conducts. Hence the voltage at collector of the phototransistor and in-

verting input of LM324 go 'low', and thus output of LM324 becomes logic 'high'. So rotation of the speedometer cable results in a pulse (square wave) at the output of LM324. The frequency of this waveform is proportional to the speed.

Let 'N' be the number of pulses in time 't' seconds and numerically equal to the number of kilometres per hour (kmph). For a vehicle such as LML Vespa, with a wheel circumference of 1.38 metres, and number of pulses equal to 10 per revolution, we get the relationship:

$$\frac{N \text{ pulses}}{t} = N \text{ kmph}$$

$$= \frac{N \times 1000}{3600 \times 1.38} \text{ metres per second}$$

$$= \frac{N \times 1000 \times 10}{3600 \times 1.38} \text{ pulses per second}$$

Therefore, time 't' in seconds = 0.4968 second.

As shown in the timing diagram, at t=0, output of astable flip-flop IC1(a) i.e. ½556 goes low and triggers monostable multivibrator IC1(b) i.e. ½556. Pulse width of monostable IC1(b) = 0.5068 sec. For IC1(a), t(on) = 0.51 sec. and t(off) = 0.01 sec. The outputs of IC1(a) and IC1(b), and the signal from the transducer section are ANDed. The number of pulses counted during the gating period (0.4968 sec.) is the speed N in kmph (kilometres per hour).

At the end of the gating period, output 'B' of monostable IC1(b) goes low and B goes high. The rising edge of B is used to enable the quad 'D' flip-flops IC6 and IC7.

At this instant, i.e. at t=0.5068 sec., the number (speed) N will be latched corresponding to the 'D' flip-flops and displayed. At t=0.52 sec., output of astable flip-flop IC1(a)

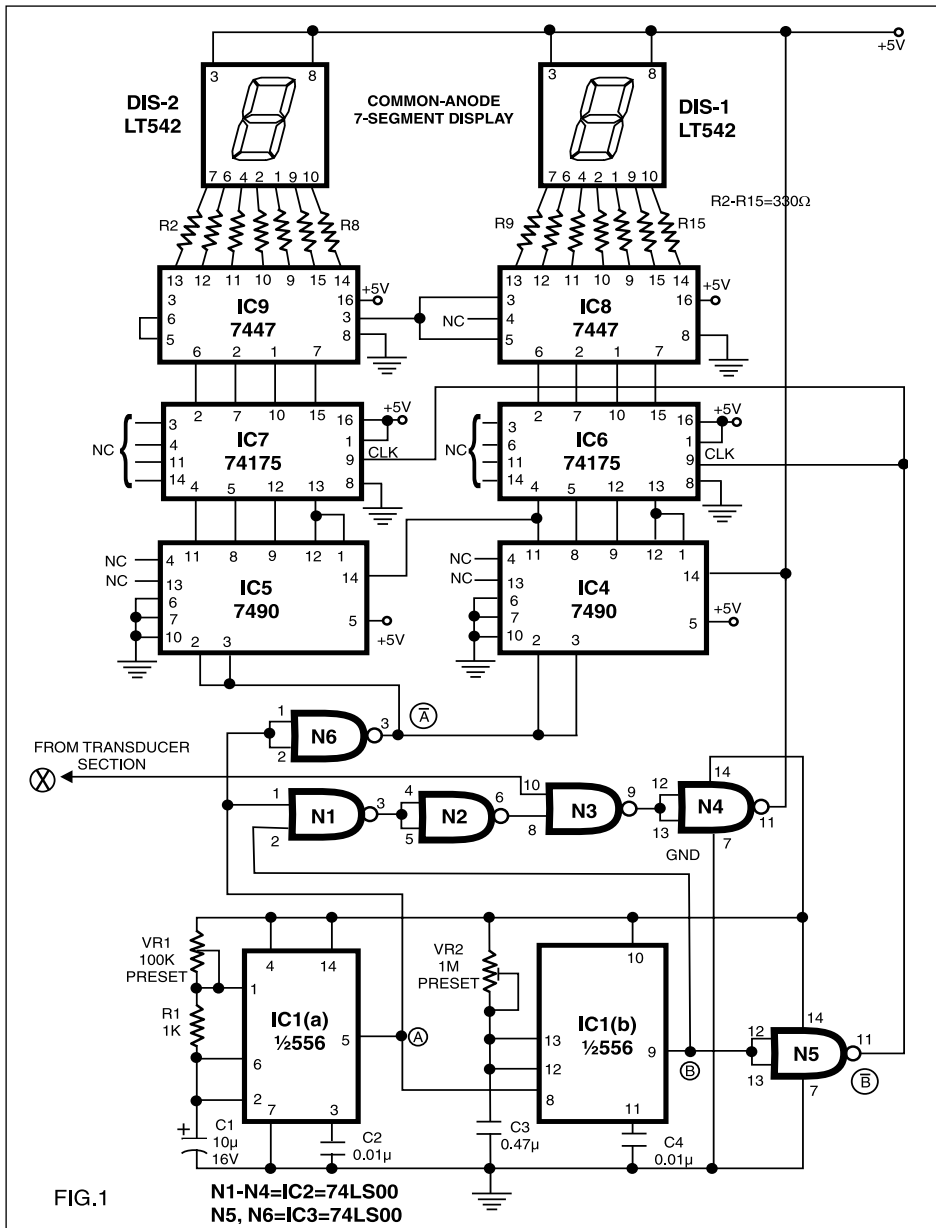

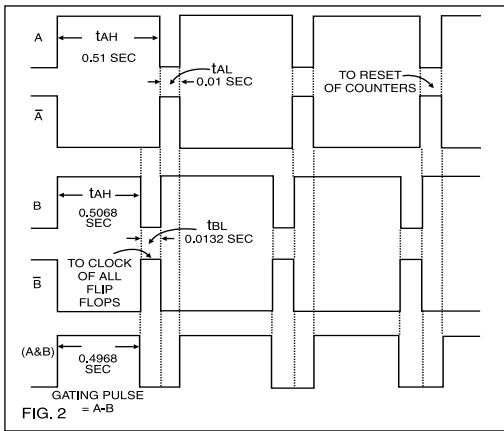

Thus the counters are reset and counting begins afresh at  $t=0.53$  sec. up to the time  $t=0.52+0.2068$  sec. However the 'D' flip-flops are not enabled and the previous speed is displayed. The new speed is displayed at  $t=0.52 + 0.5068$  sec. In this way the speed will be updated every 0.52 sec.

This speedometer can measure up to 99 kmph with a resolution of 1 kmph. The range can be increased up to 999 kmph by adding another stage consisting of one each of ICs 7490, 74175, 7447 and

The calculations shown above are for LML Vespa and Kinetic Honda. The calculations for using this speedometer for Yamaha, whose circumference of wheel = 1.8353m, can be obtained in a similar fashion. The gating period will simply vary in direct proportion to the wheel diameter. It will be 0.6607 sec. for Yamaha.

The same speedometer can be used for other vehicles by making similar calculations. In all the calculations it has been assumed that the speedometer cable makes one revolution for every revolution of the wheel of the vehicles. Note that

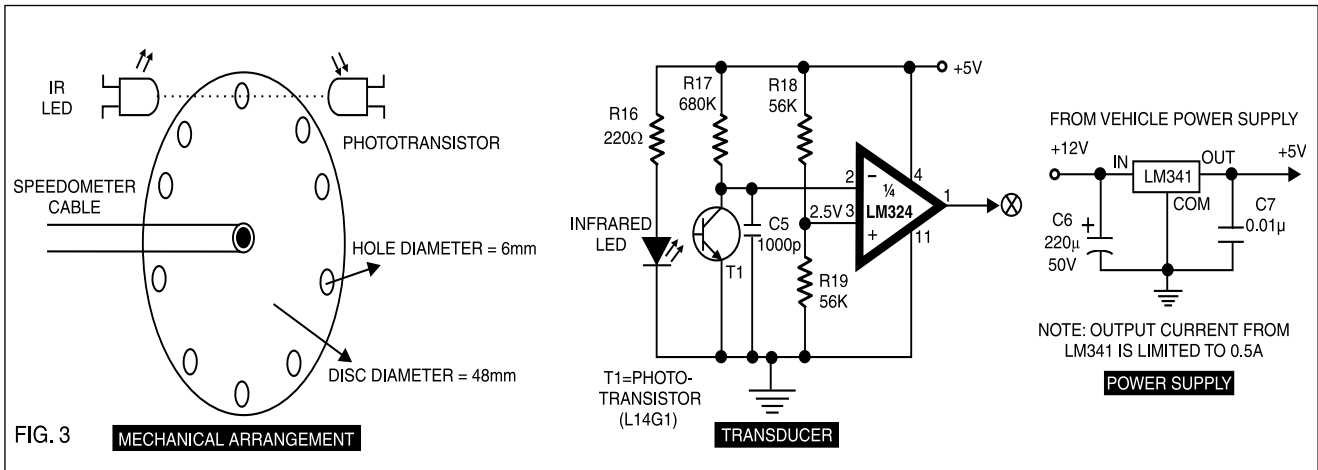

goes low and remains low for 0.01 sec. This waveform is inverted and applied to the reset terminals of all counters (active high).

a 7-segment display. The voltage supply required for the operation of the circuit is derived from the vehicle power supply (12V).

on/off periods of the wave-forms have to be precise. High quality multiturn pots and low temperature coefficient components should be used in the timer ICs.